

SMART ENERGY POWERS YOUR LIFE



TGPRO

TGPRO NEW ENERGY AUSTRALIA

🌐 www.TGPROENERGYAUS.com.au

✉ info@TGPROENERGYAUS.com.au

📍 8/88 Magowar Rd , Girraween 2145

TGPRO

**Residential Smart Solar
Storage Solution**

TGPRO NEW ENERGY AUSTRALIA

ABOUT TGPRO

Company Profile

TGpro New Energy Technology Co., Ltd. as a leader in the new energy power supply system manufacturing industry and a leading provider of solutions, has been awarded the title of National High-tech Enterprise.

Since its establishment in 2007, the company has been rooted in Dongguan, Guangdong, China, a world renowned manufacturing city. Our factory has successfully passed the UL, ISO 9001, ISO 14001 and ISO 45001 quality system certification audits, and our products have won many authoritative certificates such as UL1973/IEC62619/CE-EMC issued by TUV certification agencies, demonstrating our outstanding achievements in quality management and product safety.

Our product line covers residential energy storage systems, trigeneration energy storage systems, and off-grid hybrid solar inverters. At the same time, the R&D center located in the Songshan Lake National High-tech Industrial Park in China is constantly developing more innovative product lines to meet the diversified needs of the market.

Adhering to the development concept of "smart energy, adding power to your life", we continue to be committed to technological innovation and excellence, and are determined to become a leader in the global new energy industry.

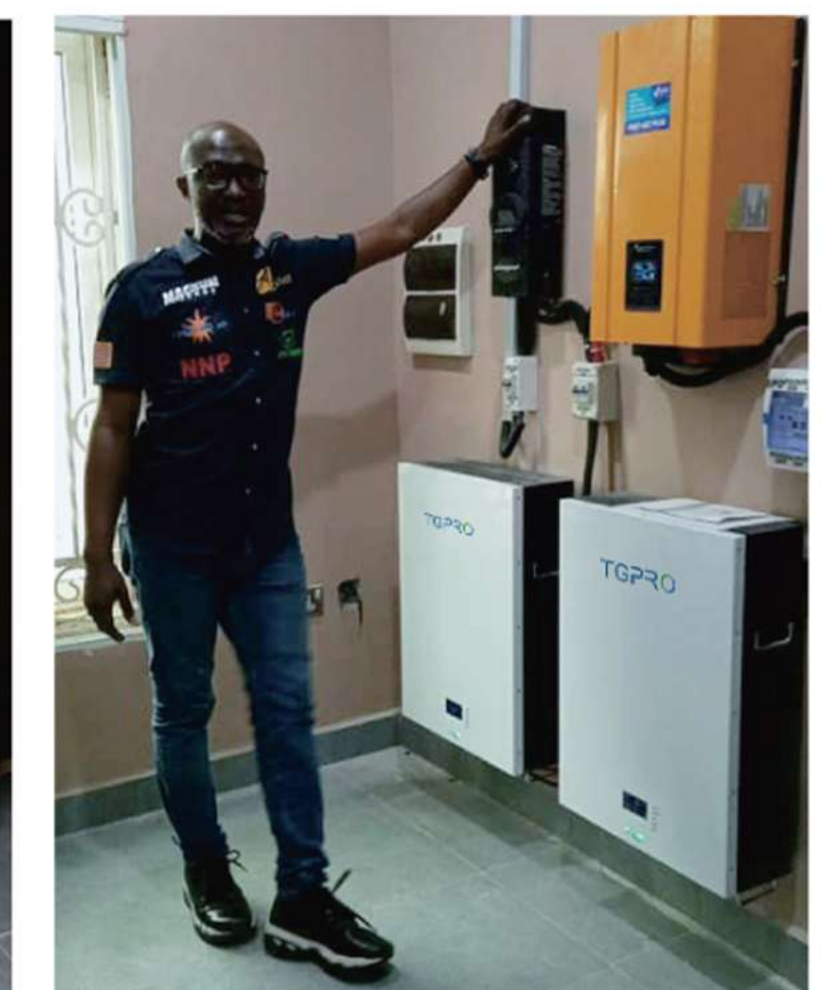

Energy storage cases- Home Energy Storage



Mississippi, USA

Home energy storage project
5kw/9.6kwh



Bochum, Germany

Household energy storage project
12 kW/15 kWh



Kuala Lumpur, Malaysia

Household photovoltaic energy storage
5kw/9.6kwh



Victoria, Australia

Integrated optical storage
5kw/10.1kWh

138 +

Exporting to more than
138+ Countries.

5 GWh+

Planning annually production
capacity 5GWH.

500 K+

Over 500,000+ Systems
installation.



Development History

2007

The factory was established, and began R&D, production, and sales of lithium batteries.

2018

Wall-mounted LiFePo4 home energy storage products were launched and sold.



2012

The company established the BMS research center and obtained ISO certification.

2019

Rack-mounted LiFePO4 home energy storage products were launched and sold. The same year, the home energy storage products received the IEC62619 certification from TUV.



2025

TGPro Products achieved a global installation capacity exceeding 10GWh, Establishing a sound service system in the whole world, more new products coming....

2023

Home energy storage products obtained UL certification from TUV. Products achieved a global installation capacity exceeding 5GWh, with over 500,000 sets of energy storage systems operating smoothly in more than 130 countries and regions.



Thailand

Energy storage expansion
50 kW/266 kWh



Niger, Africa

Off-grid optical storage system
1.25 MW/4 MWh



Philippine Islands

Solar-battery-diesel microgrid system
50 kW/103 kWh



Tangshan, Hebei

Peak shaving and frequency regulation
10MW/20MWh



Tanzania

Solar-battery-diesel microgrid system
50 kW/130 kWh



Southeast Asia Myanmar

Solar cell-diesel microgrid system
0kW-100kW/100kWh-300kWh

Energy storage cases- Industrial and commercial



Sihanoukville, Cambodia

40ft container 500 kW/1.26 MWh



France

PV+storage - 50 kW/102 kWh



Australia-Fremantle

Smart Microgrid and VPP-100kW/670kWh

2020

Commercial and industrial energy storage and high-voltage stack products were launched and sold.



2021

Self-developed off-grid, single-phase, and three-phase hybrid inverters were launched and sold.



2022

All-in-one ESS were launched and sold.



ABOUT TGPRO

ODM one-stop service

TGPRO provides one-stop energy storage system ODM services, and cooperates with customers to create energy storage products covering household, communications, industrial and commercial, public utility, special equipment and many other fields, helping customers to complete their product blueprints.

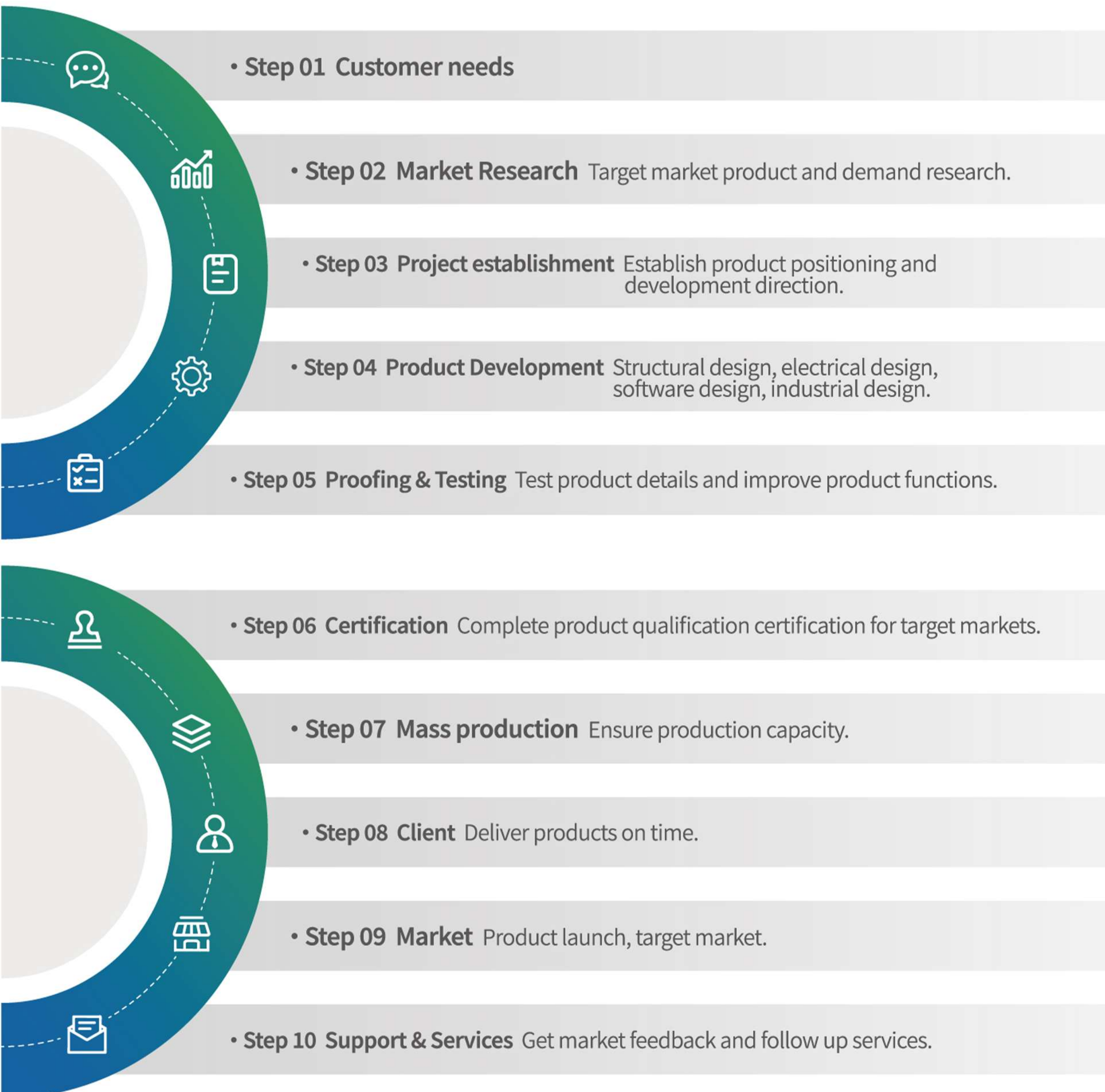

Project Cases





OEM high quality service

- ✓ Accurate understanding of customer needs.
- ✓ Detail processing, keep improving.
- ✓ Automated production line, safe and efficient.
- ✓ Delivery time and quality, double guarantee.



ENTERPRISE ADVANTAGES

Factory Management System



Digital dashboards and analytics

Reports, alarms, real-time dashboards and operational dashboards.



Intelligent logistics and distribution

Optimize the management of material distribution from the warehouse to the production line and back to the warehouse.



Design process system integration

Product design data and process data are automatically sent to the execution system.



Job plan import and scheduling

Import the workshop-level work plan and the system will arrange the tasks.

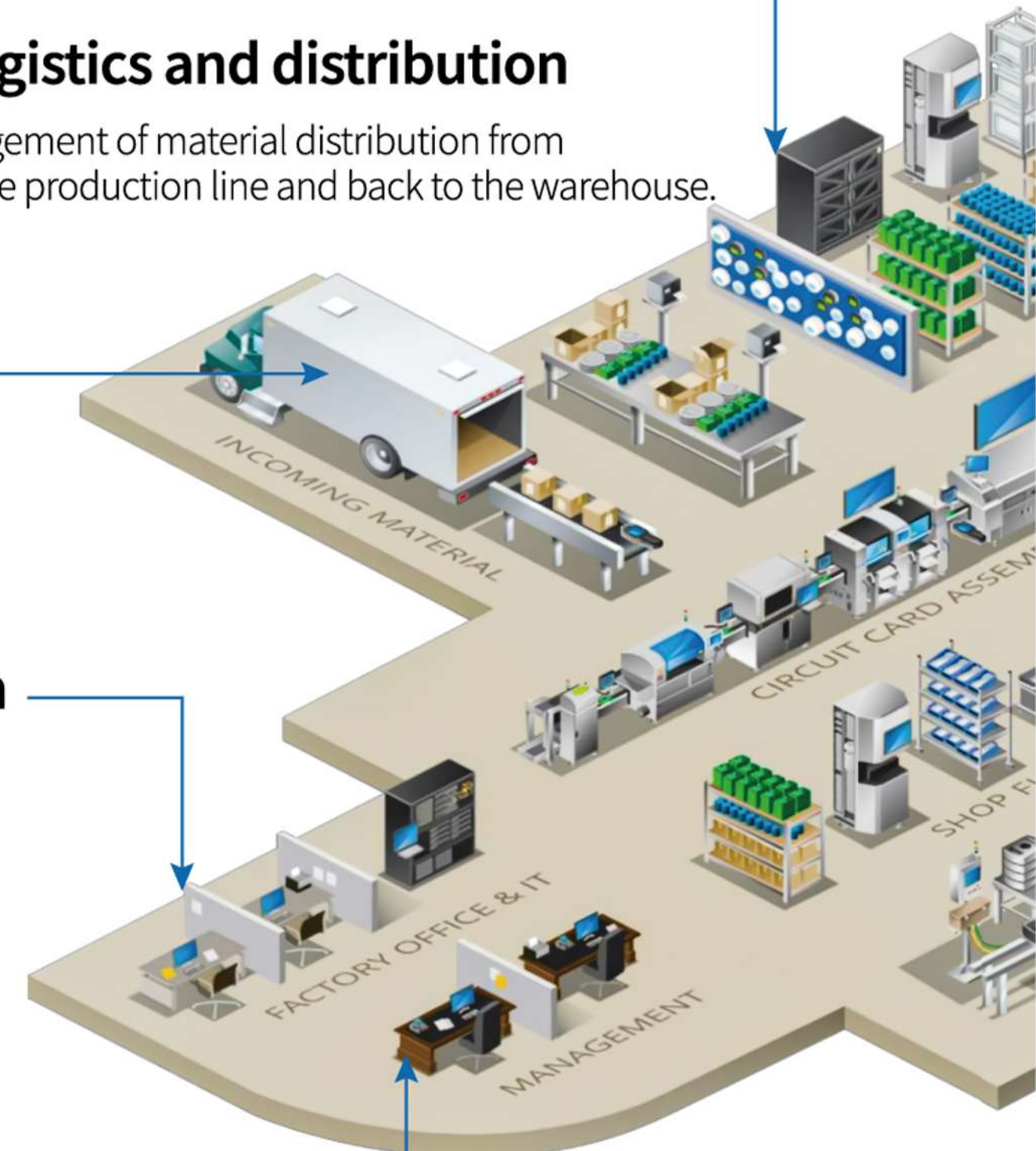

MODEL	TG-eBank-92F2
System Parameter	
System Energy (kWh)	92.16
Output Voltage Range (Vdc)	480-700.8
Cooling Method	Air cooling
Size W*D*H (mm)	750*1415*2000
Weight (kg)	1300±30kg
IP Class	IP54
Cell Battery Specifications	
Rated Capacity (Ah)	150
Standard Charge (A)	75
Rapid Charge (A)	150
Standard Charge Cut-off Voltage (V)	3.65
Standard Discharge Cut-off Voltage (V)	2.5
Standard Discharge (A)	75
Max. Discharge current (A)	150
Operating Temperature Range	-30°C~55°C
Storage Temperature Range	-30°C~60°C
Technical Parameters Of Battery Cluster	
Cell combination	192S1P
Rated Capacity (Ah)	150
Charge Voltage (V)	672
Max. Charge Current (A)	75
Max. Discharge Current (A)	90
Discharge Cut-off Voltage (V)	480
Charge Temperature Range	0°C~55°C
Discharge Temperature Range	-20°C~55°C
Storage Temperature	-20°C~50°C
Single Pack Size W*D*H (mm)	522*1039*200
Single Pack Weight (kg)	125
IP Class	IP54

System Topogy

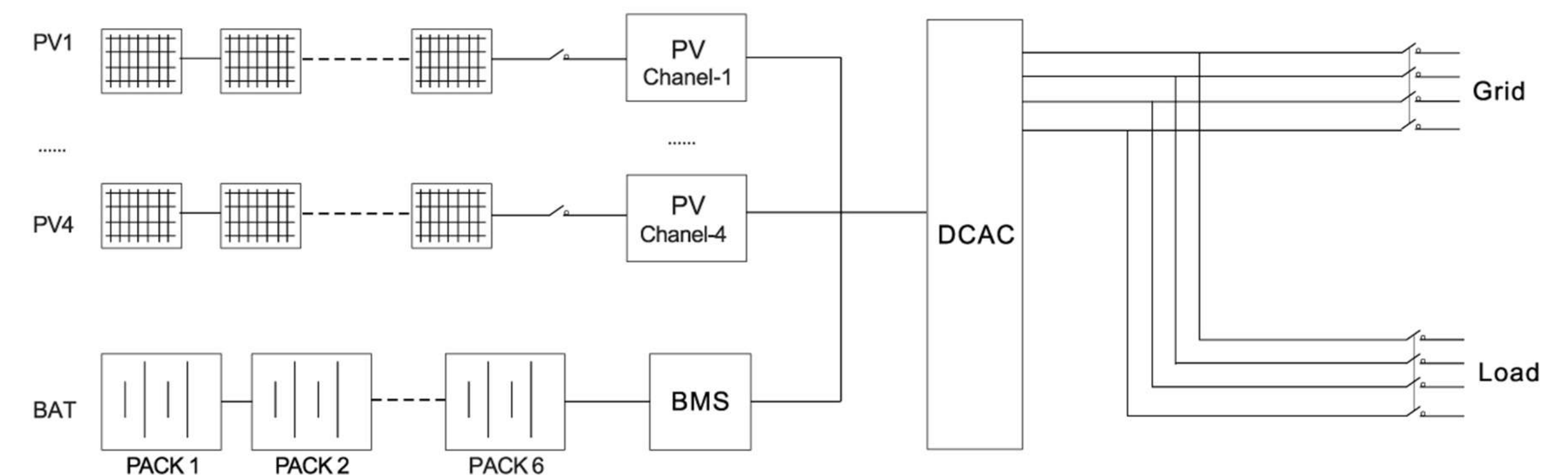



TG-eblock-92F2



Features

- Strong scalability, simple & convenient expansion on both AC and DC sides
- With self-use, peak shifting, forced charging & discharging and other working modes
- Easy to install and deploy with large space utilization
- Unique modular design & flexible function configuration

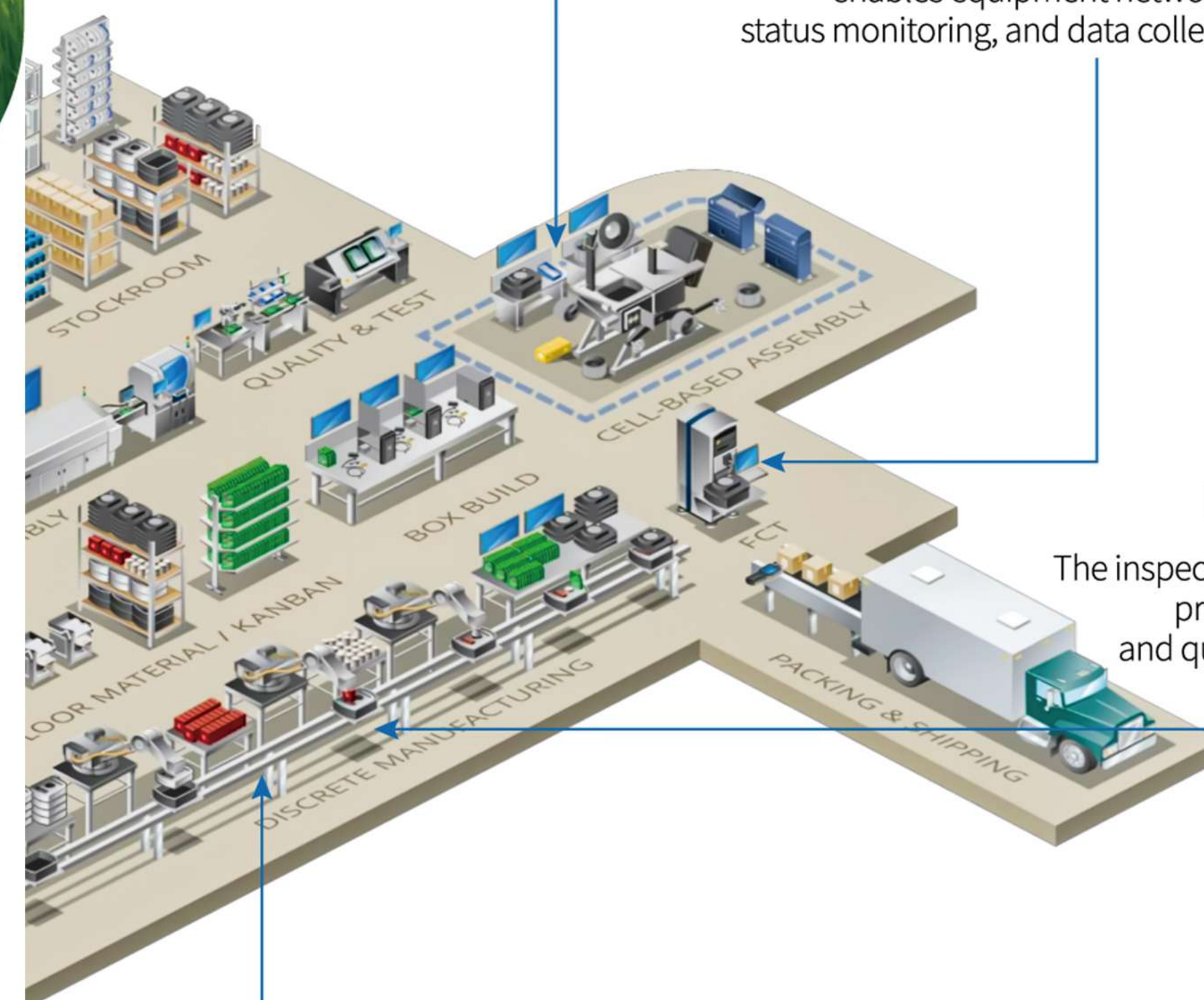

Full quality traceability and analysis

Based on the traceability analysis of the entire production cycle of the product, monitor and discover defects in time to improve quality.

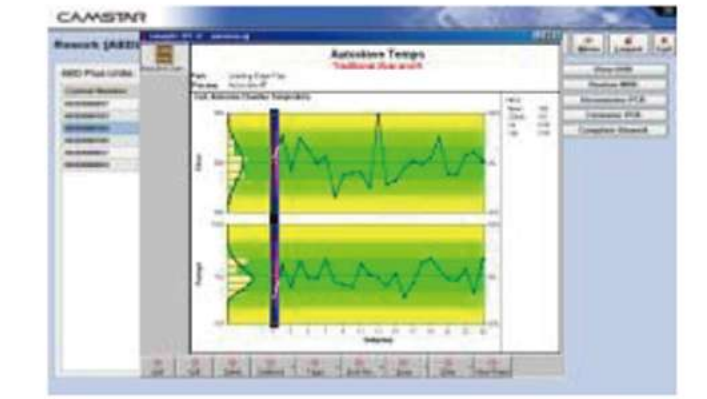

Equipment status monitoring and data collection

The underlying industrial control network enables equipment networking, status monitoring, and data collection.



Digital quality inspection

The inspection indicators constrained by standard processes complete the digital inspection and quality data collection of single products.



Paperless production process control

Paperless process execution, process tracking, data collection/analysis and production process monitoring and management.



ENTERPRISE ADVANTAGES

R&D system



Structural design



Electrical Design



Fluid Simulation Design



BMS and PCS professional matching

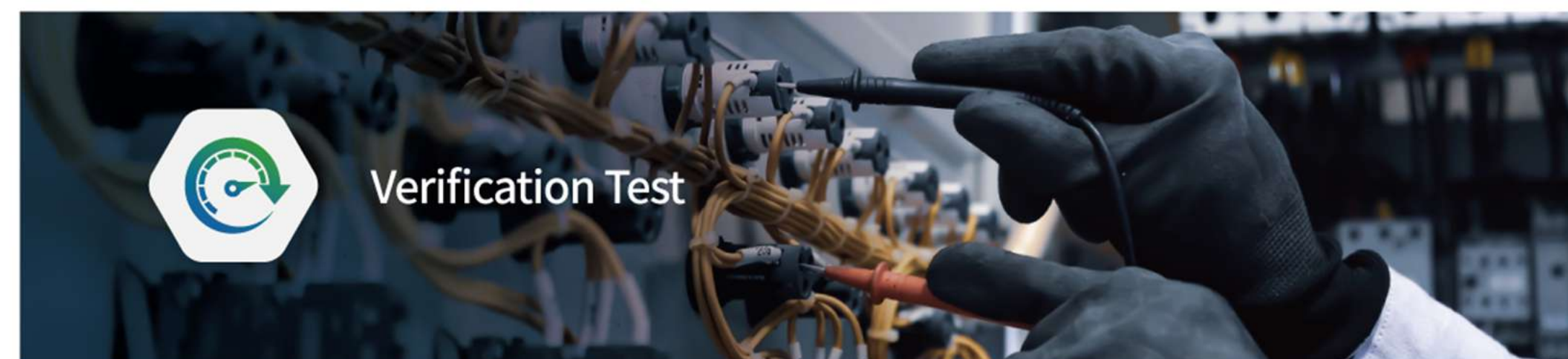

Verification Test

MODEL	TG-6KW/9.6kWh	TG-6KW/19.2kWh	TG-10KW/9.6kWh	TG-10KW/19.2kWh
PV Specifications				
Max. Recommended PV Array Power(Wp)	12000	13000	20000	20000
Max. PV Input Voltage (V)	600			
Start-up Input Voltage (V)	50			
MPPT Voltage Range (V)	40-560			
No. Of MPPT/Strings Per MPPT	2(1/1)		4(1/1/1/1)	
Max. PV Input Current (A)	32(16/16)		64(16/16/16/16)	
Input/Output (Grid)				
Max. AC Input Power From Grid (VA)	12000	13000	14500	14500
Rated AC Output Power (W)	5000	6000	10000	10000
Max. AC Output Power (VA)	5000	6000	10000	10000
Max. AC Output Current (A)	22.8	27.3	45.5	45.5
Rated AC Voltage (V)	220/230/240			
AC Voltage Range (V)	154-276			
Rated Grid Frequency (Hz)	50/60			
Grid Frequency Range (Hz)	45-55/55-65			
Total Harmonic Distortion (Rated Power)	< 3%			
Power Factor At Rated Power	> 0.99%			
Adjustable Power Factor	adj. 0.8 leading to 0.8 lagging			
Battery Data				
Rated Voltage (Vdc)	192	384	192	384
Cell combination	60S1P	120S1P	60S1P	120S1P
Rated Capacity (Ah)	50			
Energy Storage (kWh)	9.6	19.2	9.6	19.2
Cycle life	25±2°C, 0.5C/0.5C, EOL70%≥6000			
Max. Charge/Discharge current (A)	30		50	
Discharge Cut-off Voltage (Vdc)	162	324	162	324
Charge Cut-off Voltage (Vdc)	219	438	219	438
Environment				
Charge Temperature Range	0°C~55°C@60±25% Relative Humidity			
Discharge Temperature Range	-20°C~55°C@60±25% Relative Humidity			
Storage Temperature	-20°C~50°C@60±25% Relative Humidity			
Mechanical				
IP Class	IP65			
Material System	LiFePO4			
Case Material	Metal			
Case Type	All In One Stack			
Package Dimension L*W*H (mm)	800*188*1275	800*188*1798	800*188*1275	800*188*1798
Product Dimension L*W*H (mm)	Battery outer packaging L920*W310*H750mm Inverter outer packaging L915*W600*H305mm Main control box outer packaging L890*W275*H380mm			
Net Weight (kg)	Inverter high-voltage box: 47kg Battery box: 101kg Main control box: 9.5kg			
Gross Weight (kg)	1Inverter high-voltage box: 58kg Battery box: 141kg Main control box: 18kg			
Communication(Optional)	RS485/CAN/WLAM Optional			
Certificates	EN, IEC, NRS, G99, UN38.3, MSDS, CE			



Certification system



(UL TH-48200-W)



(UL TH-51200-EP/WP)



(UL TH-51100-R)



(CE TG-SS-LV)



(IEC 62619: 2017)

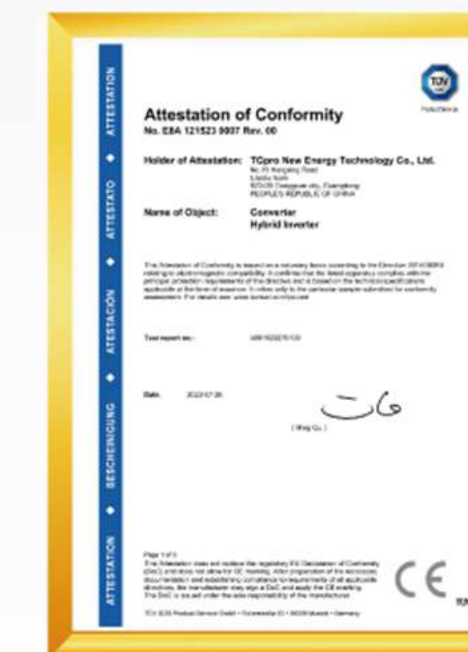

(IP-LV EU Universal Grid-Connected Certification)



(TCT TG-10KW/8.64KW)



(3P EU Universal Grid-Connected Certification)

Single Phase ESS Series



Product Highlights

Plug & Play

Plug & Play stackable design,
10 minutes fast commissioning.

Active Safety

AFCL active arcing protection.

Efficiency

Up to 98.4% European 97.9%.

More Options

2*9.6 kWh battery module
+ Optional battery stack.



ENTERPRISE ADVANTAGES

Quality System

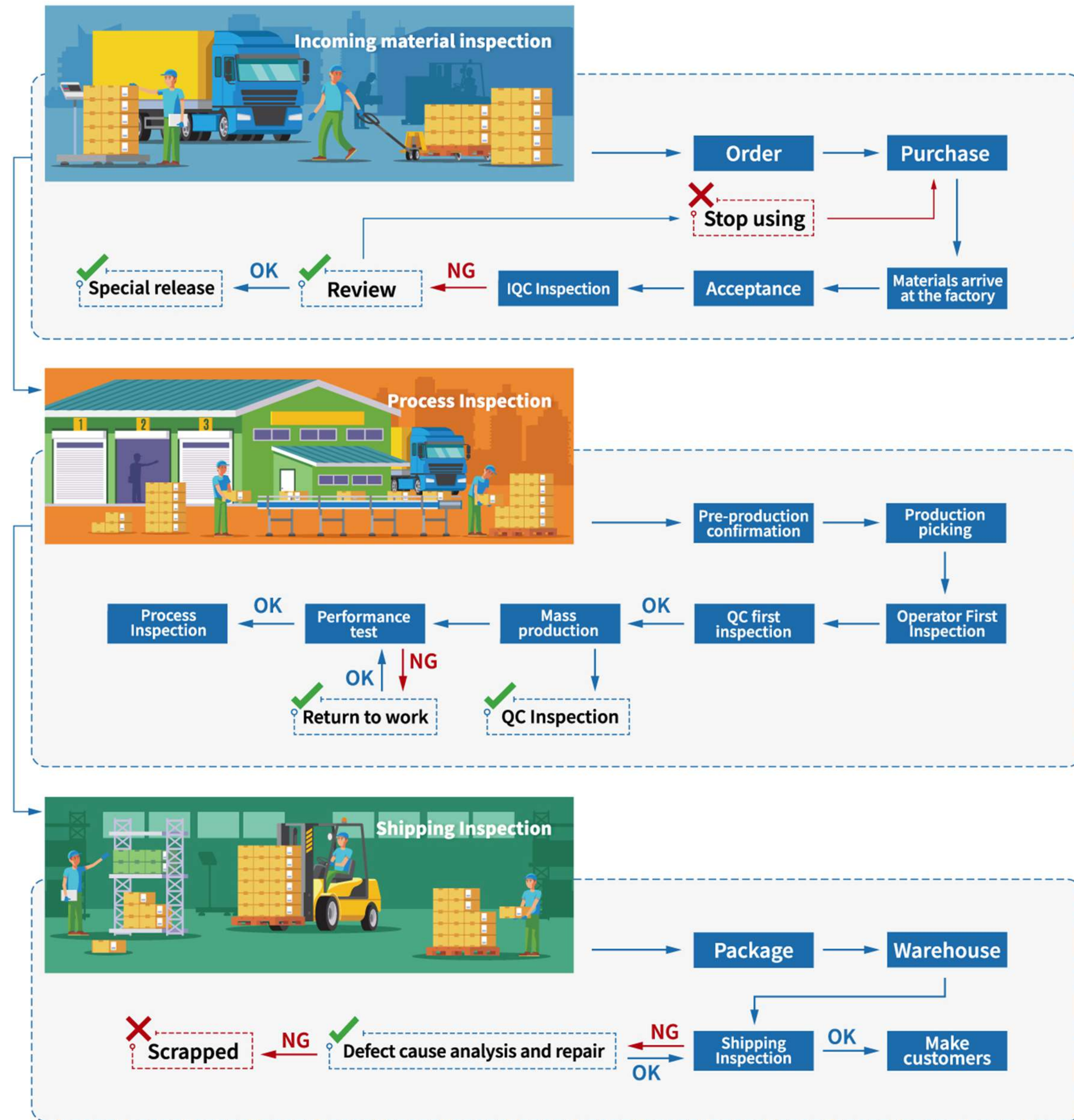

(System quality assurance, continuous certification update S09001/IS014001/IS045001)

MODEL	TG-ESS-9HV-S1	TG-ESS-9HV-S2
PV Specifications		
Max. PV Input Power	15000W	
Nominal DC Voltage/Voc	600Voc	
Start-up/Min. Operation Voltage	180Vdc	
MPPT Voltage Range	150-950Vdc	
No. Of MPPTs/Strings	2(1/2)	
Max. PV Input Current	48A(16A+32A)	
INPUT/OUTPUT(AC)		
Max. AC Input Power From Grid	20500VA	
Rated AC Output Power	10000W	
Max. AC Output Apparent Power	11000VA	
Rated/Max. AC Output Current	15.2A/16.7A	
Rated AC Voltage	3/N/PE 220V/380V 230V/400V 240V/415V	
AC Voltage Range	270-480V	
Rated Grid Frequency	50Hz/60Hz	
Grid Frequency Range	45~55Hz/55-65Hz	
Harmonic(THD)(Of Rated Power)	< 3%	
Power Factor At Rated Power	> 0.99	
Adjustable Power Factor	0.8leading...0.8lagging...	
AC Type	Three phase	
BATTERY DATA		
Rate Voltage(Vdc)	192	384
Cell combination	60S1P*1	60S1P*2
Rate Capacity(Ah)	50	
Energy Storage(kWh)	9.6	19.2
Cycle life	25±2°C, 0.5C/0.5C, EOL70%≥6000	
Max. Charge/Discharge Current(A)	30	
Discharge Cut-off Voltage(VDC)	162	324
Charge Cut-off Voltage(VDC)	216	432
ENVIRONMENT		
Charge temperature	0°C~55°C@60±25% Relative Humidity	
Discharge temperature	-20°C~55°C@60±25% Relative Humidity	
Storage temperature	-20°C~50°C@60±25% Relative Humidity	
MECHANICAL		
IP Class	IP65	
Material System	LiFePO4	
Case Material	Metal	
Case Type	All In One Stack	
Package Dimension L*W*H(mm)	Battery outer packaging L920*W310*H750mm Inverter outer packaging L915*W600*H305mm Main control box outer packaging L890*W275*H380mm	
Net weight(kg)	Inverter high-voltage box: 47kg Battery box: 101kg Main control box: 9.5kg	Inverter high-voltage box: 47kg Battery box: 101kg*2 Main control box: 9.5kg
Gross weight(kg)	Inverter high-voltage box: 58kg Battery box: 141kg Main control box: 18kg	
COMMUNICATION		
Protocol(Optional)	RS485/CAN/WLAN Optional	
CERTIFICATES		
EN, IEC, NRS, G99, UN38.3, MSDS, CE		



Three Phase ESS Series



Product Highlights

Plug & Play

Plug & Play stackable design,
10 minutes fast commissioning.

Efficiency

Up to 98.4% European 97.9%.

Active Safety

AFCL active arcing protection.

More Options

2*9.6 kWh battery module
+ Optional battery stack.

After-sales system



Network layout

The after-sales service stations jointly built with customers have now completed their network layout in the South African, Pakistan market.



Service System

Service outlets + spare parts warehousing
+ logistics + recycling.

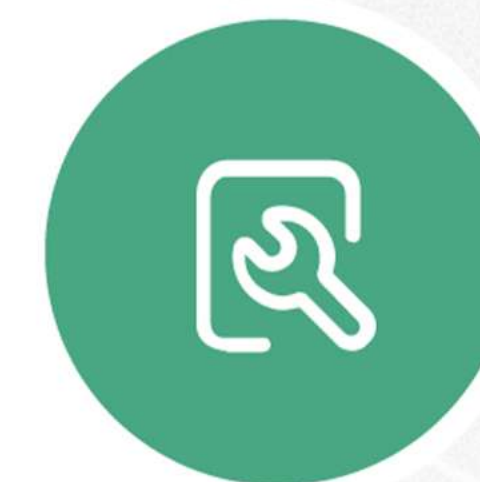

System Services

Routine maintenance and debugging
+ customer guidance and training
+ spare parts support
+ regular inspections during the warranty period.

TGPRO ESS ALL in ONE

TGPRO All in one energy storage system with modular structure. Range from home use to commercial use. Integrated with PV, AC, battery in one system with flexible settings of working principle. Solution is provided to meet different customer demands.

Solution:

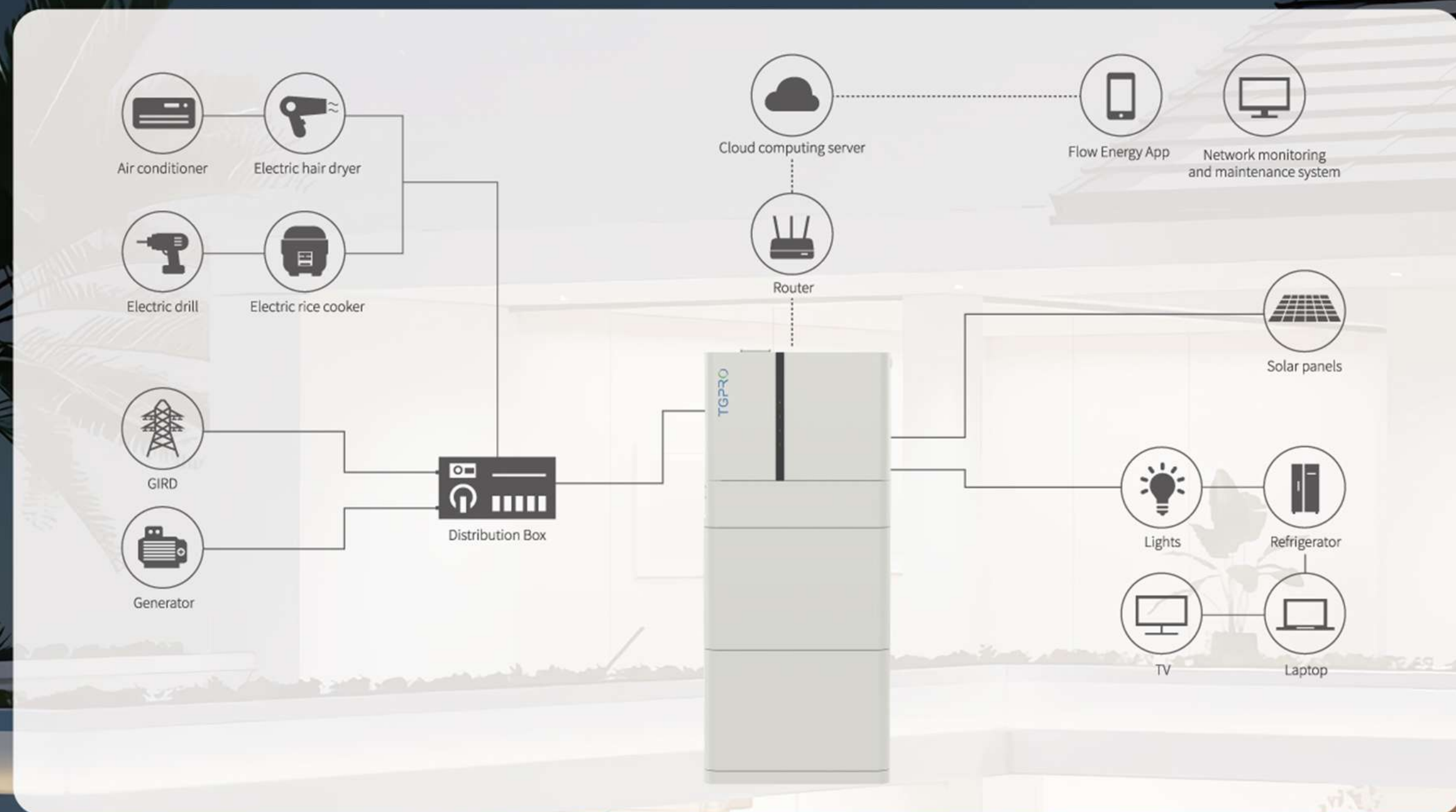

Features:

- Integrated design, quick commissioning.
- Only A-grade batteries are used for all battery packs.
- Strict quality management system ensures low failure rate.
- Easy to maintain, one supplier, one solution and one service window.